

Step 1:

Open the bonnet, standing in front of the car, look at the bonnet catch, remove the left hand bolt – this allows clearance to get the slam panel on without bending it.

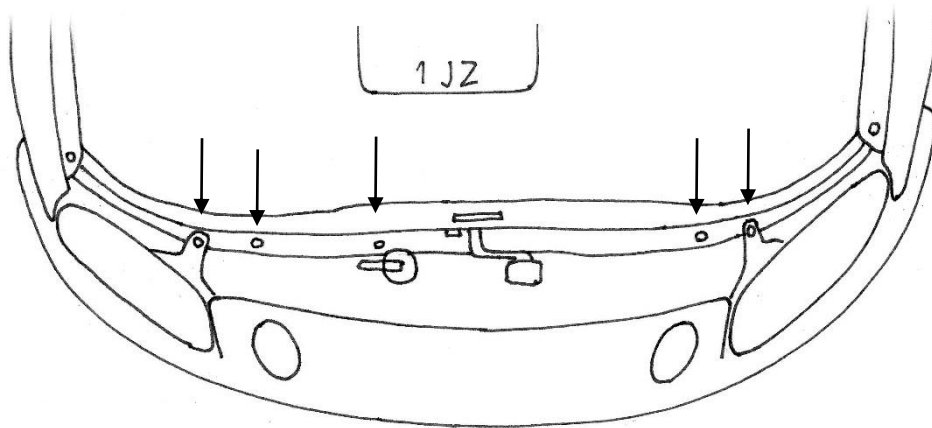

Step 2:

Undo the two headlamp securing bolts, and the three bolts in the slam panel. Careful – the outer two support your bumper so be gentle from now on.

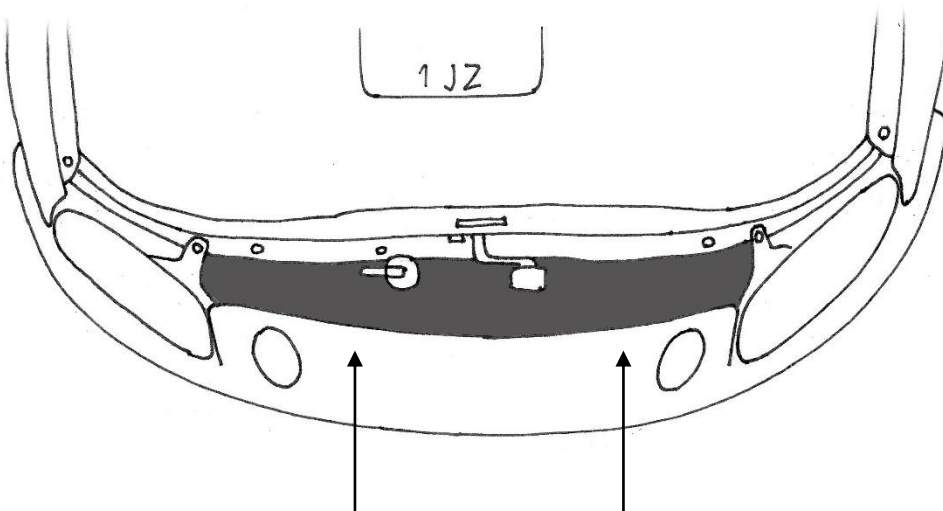

Step 3:

Carefully slot the middle section into place. You might need to gently pull on the bumper where the arrows suggest to get it in. It's a snug fit!

P.T.O.

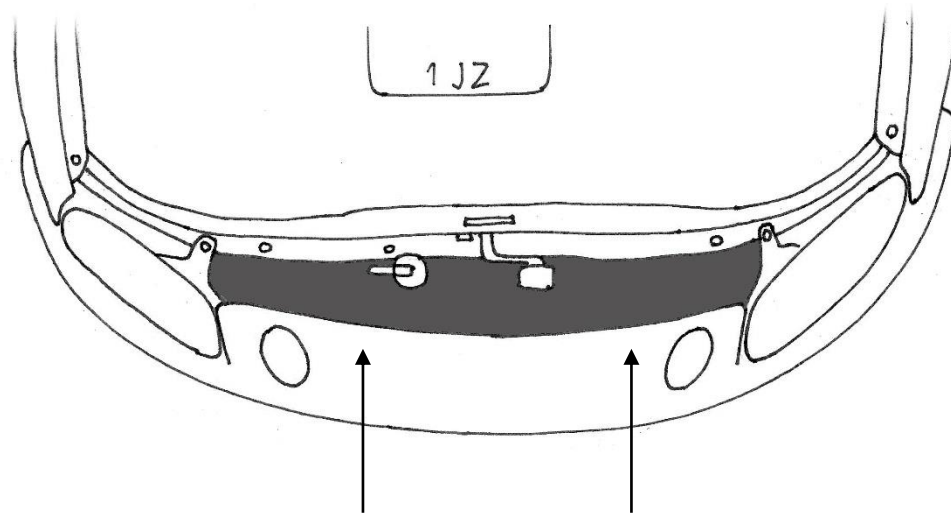

Step 3: (cont.)

If your car has had a knock in the past, you might need to file a touch off the panel to get it in, be extremely careful of the top surface of finish.

Cover along the edge you need to file in masking tape to protect the finish, a filed edge will not be visible once fitted so do not worry!

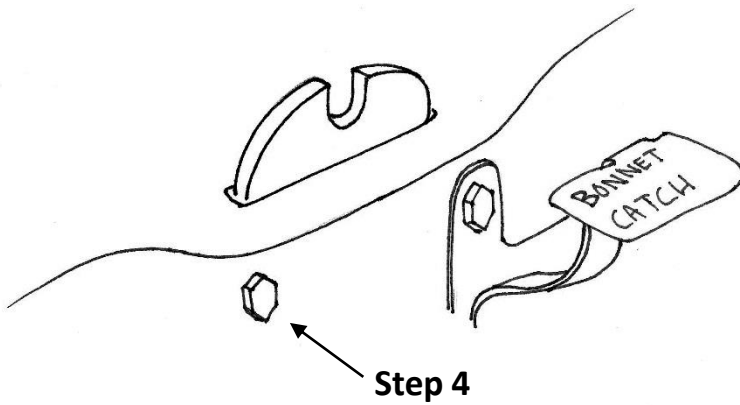

Step 4:

Refit the bolt from your latch, push gently on the panel for clearance.

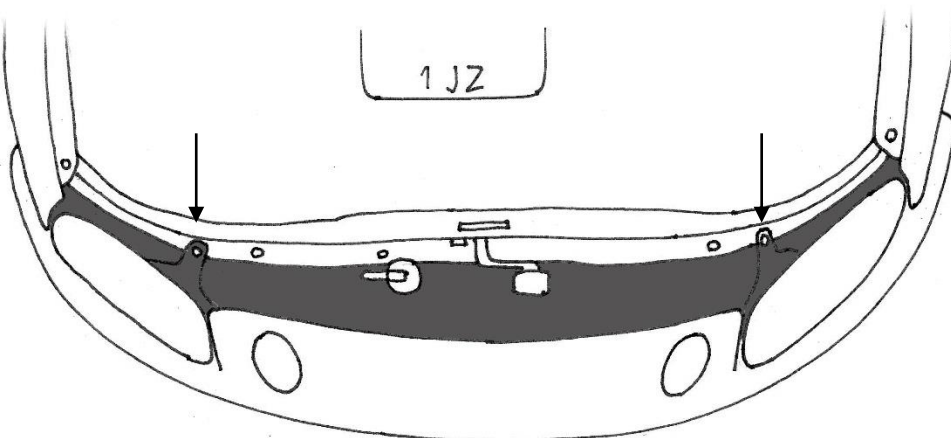

Step 5:

Now fit the headlamp tops, the curves go downwards and they should literally bolt straight on, nip up the bolts to stop them moving.

Step 6:

Smile, your engine bay just got a whole lot neater – and has perfect air flow into your radiator.